

# Voltage Regulator

v1.2

## Features / Benefits

- Provides on-chip regulated supply to drive hundreds of gates
- Can act as a reference for slave regulators to drive more current
- 1 MHz cutoff frequency

## Product Description

Master voltage regulator, crba\_vreg, receives the core supply or other voltage level as a reference voltage. This reference voltage is filtered through a low pass filter with a cut-off frequency of approximately 1MHz. The processed reference voltage is then compared against a reference voltage generated off the VDDA supply and augmented with a low impedance source follower to provide the internal regulated voltage. The voltage regulator can drive up to 100 simultaneously switching standard cell drivex4 gates with less than 10mV supply noise using the VREG output. The gate voltage of the source follower is also provided as the VM pin to enable the addition of Slave regulators, which are incorporated into the IO templates for additional driving capability.

The voltage regulator serves to address power management or provide clean supply to timing critical blocks minimizing delay modulation and uncertainty due to supply noise.

## An SoC Approach

LiquidMXS is integrated along with LiquidIO and LiquidCell to create highly integrated, efficient and comprehensive LiquidPHY subsystems. Readily integrated subsystems addresses many challenges and concerns associated with high speed interface designs.

## Applications

- On-chip voltage regulation for circuits requiring a clean or independent supply.

crba\_vreg physical implementation

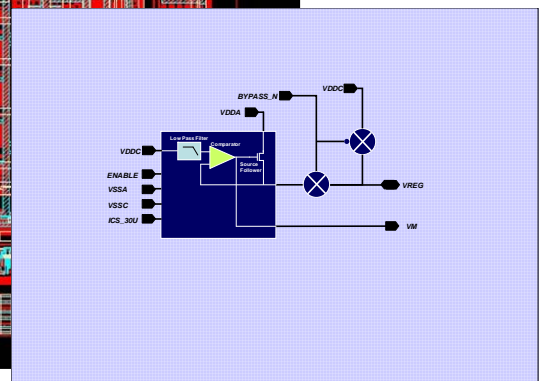
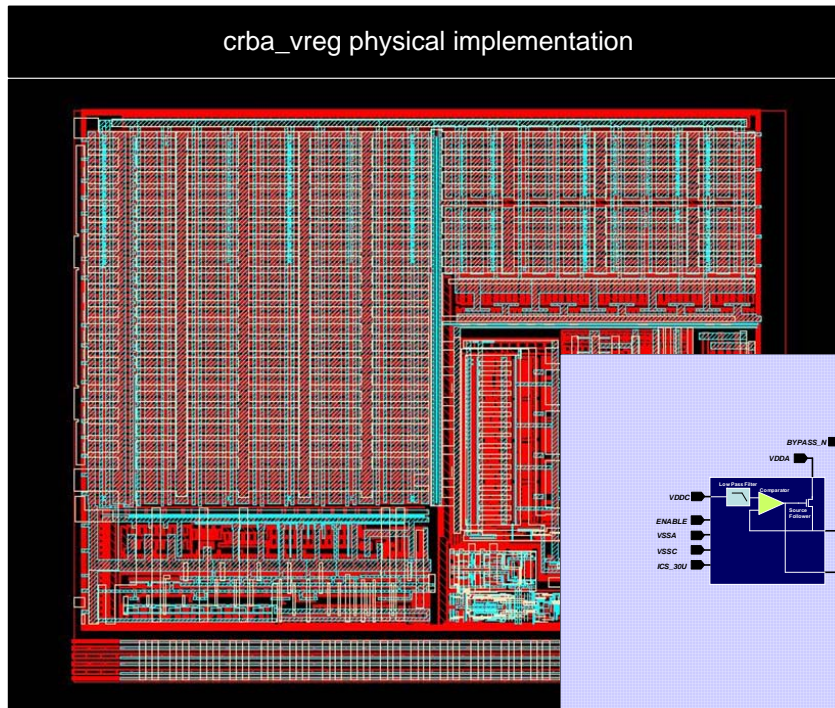

Block Diagram