

Crystal Oscillator (32KHz/8-36MHz) IO Cell

v1.2

Features / Benefits

- 32KHz XTAL operating @ < 16μW RMS
- 32KHz Xtal single 1.2V supply for sleep mode applications
- 8-36MHz XTAL operating @ < 200μW RMS
- 8-36MHz XTAL IO supply of 1.8V or 2.5V
- 8-36MHz XTAL incorporates power and drive optimization
- Input Hysteresis of 25mV
- IDDQ and parametric Nand test functions
- Metal programmable within Rapid Bridge platform
- ESD 2kV HBM, 200V MM, 500V CDM
- Wirebond, Flip Chip and CUP versions available
- IEEE 1149.1 Compliant

Applications

- PLL Reference Clock

Product Description

32KHz and 8-36MHz Crystal Oscillators are designed using three-point oscillator configuration. Two external capacitors and the internal components determine the proper phase shift necessary to start and maintain the desired frequency of operation. 32KHz and 8-36MHz oscillators operate on a 1.2V and 1.8/2.5V supplies, respectively. 32KHz oscillator requires an additional 10MΩ external resistor across it's terminals to complete the feedback path. Both oscillator are low power to allow for sleep mode conditions.

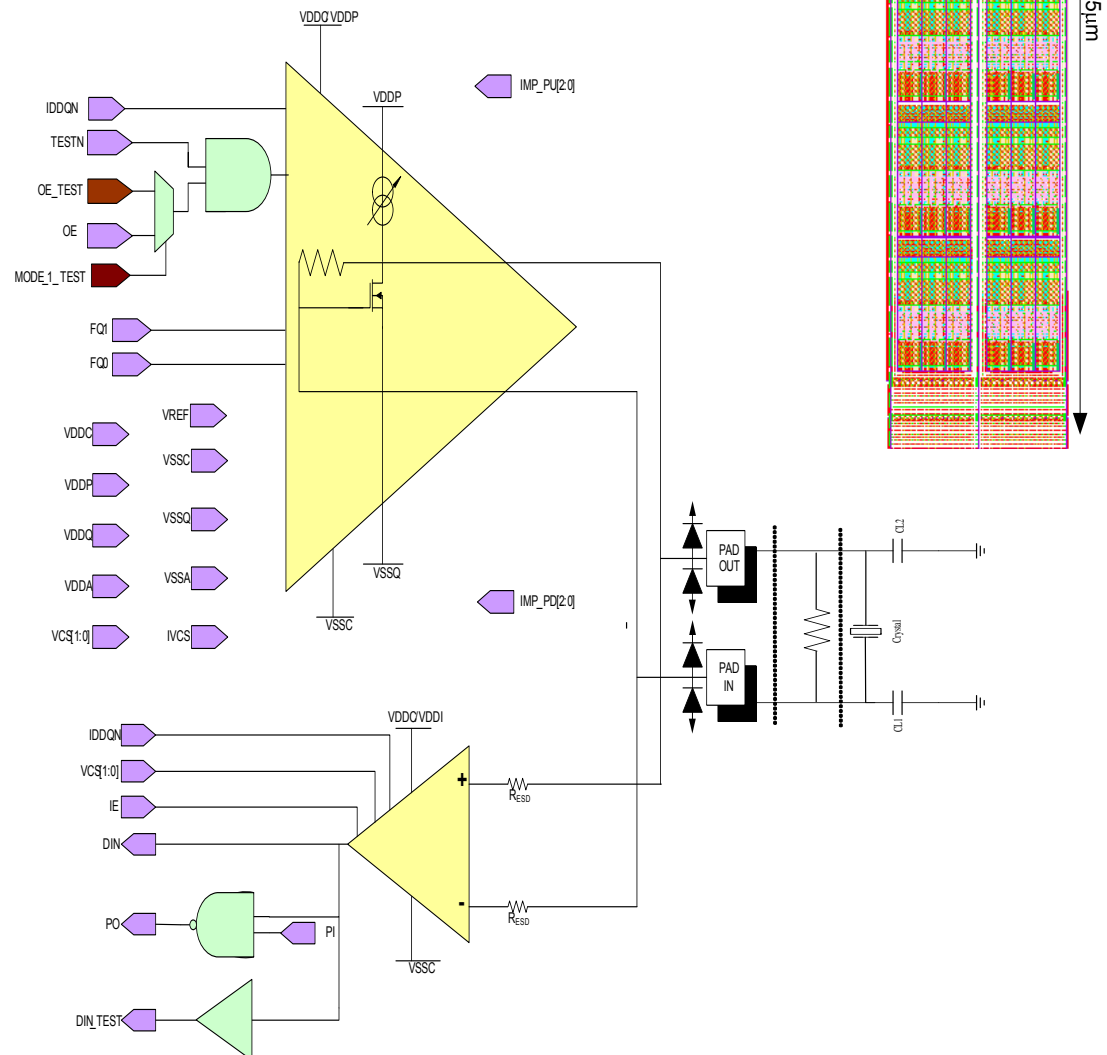

Crystal Oscillator (32KHz/8-36MHz) IO Cell

Complete Interface Solution

Crystal Oscillator interfaces are part of a complete IO ring solution, which has been specifically designed for high performance, easy chip integration, and flexible system level requirements. This top-level integrated IO design approach eliminates redundant components, such as multiple bias generation and calibration circuits, and prevents power supply fragmentation, leading to smaller area, lower power utilization, and better ESD protection.

Because the IOs are designed to work together, test methodology has been greatly simplified as well. Parametric Nand trees, JTAG scan chains, and IDDQ testing can all be accomplished with minimal circuits and control lines.

Proprietary software available from Rapid Bridge may be used to help create correct-by-construction IO rings with mixed IO types and the proper number of support pads for a successful design. IOCalculator software is a WEB based tool that allows end users to calculate power pad requirements based on packaging and system specifications for the supported standard within LiquidIO family. RingComposer is used to compose the entire ring and the respective support circuits based on output of IOCalculator. Test functions are composed and are correct by construction. System level ESD results in better than 2kV HBM, 200V MM and 500V CDM models. Combination of the above tool sets and metal programmability creates a complete liquid infrastructure allowing full flexibility and re-programmability.

For More Information. . .

Regarding LiquidIP™, LiquidASIC™, or LiquidSoC™, please contact Rapid Bridge at:

sales-support@rapidbridge.com or visit www.rapidbridge.com

Performance Beyond the Past

XTAL 32KHz and 8-36MHz are part of a harmonious system that is calibrated through a Central Calibration Unit across process and temperature. This yields significant improvement in rms and peak currents of up to 60%, reducing top level system requirements. Reduction in power is coupled with well matched and balanced output impedances that enhances signaling and performance throughout the system. Systematic implementation of the LiquidIO subsystem eliminates potential, difficult to address, interface interactions.

Silicon results of the 32KHz Crystal Oscillator



Silicon results of the 35MHz Crystal Oscillator

